

Altitude™ 4600 Series Access Point Installation Guide

Extreme Networks, Inc.
3585 Monroe Street
Santa Clara, California 95051
(888) 257-3000
(408) 579-2800
<http://www.extremenetworks.com>
Published: May 2011
Part Number: 100369-00 Rev 03



AccessAdapt, Alpine, Altitude, BlackDiamond, EPICenter, ExtremeWorks Essentials, Ethernet Everywhere, Extreme Enabled, Extreme Ethernet Everywhere, Extreme Networks, Extreme Standby Router Protocol, Extreme Turbodrives, Extreme Velocity, ExtremeWare, ExtremeWorks, ExtremeXOS, Go Purple Extreme Solution, ExtremeXOS ScreenPlay, ReachNXT, Sentriant, ServiceWatch, Summit, SummitStack, Triumph, Unified Access Architecture, Unified Access RF Manager, UniStack, the Extreme Networks logo, the Alpine logo, the BlackDiamond logo, the Extreme Turbodrives logo, the Summit logos, and the Powered by ExtremeXOS logo are trademarks or registered trademarks of Extreme Networks, Inc. or its subsidiaries in the United States and/or other countries.

sFlow is a registered trademark of InMon Corporation.

Specifications are subject to change without notice.

All other registered trademarks, trademarks, and service marks are property of their respective owners.

© 2011 Extreme Networks, Inc. All Rights Reserved.

Table of Contents

Chapter 1: Introduction	7
Document Conventions	7
Warnings	8
Site Preparation	8
Package Contents	9
External Antenna Models - Package Contents (AP4620-US, AP4621-US, AP4620-ROW and AP4621-ROW)	9
Integrated Antenna Models - Package Contents (AP4610-US, AP4611-US, AP4610-ROW and AP4611-ROW)	9
Features	9
Chapter 2: Hardware Installation	11
Installation Instructions	11
Precautions	13
Access Point Placement	13
Integrated Antenna Model Wall Mount Instructions	13
Wall Mount Hardware	14
Wall Mount Procedure	14
Integrated Antenna Suspended Ceiling T-Bar Mount Instructions	15
External Antenna Wall Mount Instructions	16
Wall Mount Hardware	17
Wall Mount Procedure	18
External Antenna Suspended Ceiling Tile (Plenum) Mount Instructions	19
Suspended Ceiling Mount Hardware	20
Ceiling Mount Procedure	20
Altitude 4600 Series Antenna Options	21
LED Indicators	21
Software Version 4.x LED States	22
Software Version 5.x LED States	22
Chapter 3: Specifications	23
Electrical Characteristics	23
External Antenna Model Physical Characteristics	23
Integrated Antenna Model Physical Characteristics	24

Radio Characteristics	25
Chapter 4: Basic 4600 Series Configuration	27
Establishing Basic AP Connectivity	27
Access Point Controller Adoption	27
Chapter 5: Regulatory Compliance	29
Radio Modules.....	30
Wireless Device Country Approvals.....	30
Country Selection - Note for AP & Wireless Switch	31
Frequency of Operation - FCC and IC	31
5 GHz Only.....	31
2.4 GHz Only.....	32
Health and Safety Recommendations.....	32
Warnings for the use of Wireless Devices	32
Potentially Hazardous Atmospheres - Fixed Installations	32
Safety in Hospitals.....	32
Pacemakers.....	32
Other Medical Devices.....	33
RF Exposure Guidelines.....	33
Safety Information	33
Reducing RF Exposure—Use Properly	33
International.....	33
EU	34
Remote and Standalone Antenna Configurations	34
US and Canada.....	34
Co-located statement.....	34
Remote and Standalone Antenna Configurations	34
Power Supply	34
Radio Frequency Interference Requirements - FCC.....	35
Radio Transmitters (Part 15).....	35
Radio Frequency Interference Requirements - Canada	36
Radio Transmitters.....	36
CE Marking and European Economic Area (EEA).....	36
Statement of Compliance.....	37
Turkish WEEE Statement of Compliance	37
Japan (VCCI) - Voluntary Control Council for Interference Class B ITE	37

Korea Warning Statement for Class B ITE.....	38
Other Countries	38
Australia	38
Brazil.....	38
Chile.....	39
Mexico.....	39
Taiwan.....	39
Korea.....	41
Chapter 6: Waste Electrical and Electronic Equipment (WEEE)	43
Chapter 7: Customer Support	45
Registration.....	45
Documentation	45

An Altitude™ 4600 Series Access Point links wireless 802.11a/b/g/n devices to the controller, enabling growth of your wireless network with a cost-effective alternative to standard access points. The Altitude 4600 Series Access Point provides two placement options: wall and ceiling. Wall mount slots fit onto two screws provided. Arrows on the case guide placement of the screws. For placement above a suspended ceiling, a safety wire tie point on the case provides for a loop of safety wire. The light pipe fits through a hole in the ceiling tile to provide a view of the unit's status lights.

The Altitude 4600 Series Access Point receives all power and transfers data through the same CAT-5 or better Ethernet cable. There is no additional power supply required. A Gigabit 802.3af Ethernet controller or Gigabit power-over-Ethernet solution is required.

Document Conventions

The following graphical alerts are used in this document to indicate notable situations



NOTE

Tips, hints, or special requirements that you should take note of.



CAUTION

Care is required. Disregarding a caution can result in data loss or equipment malfunction.



WARNING!

Indicates a condition or procedure that could result in personal injury or equipment damage.

Warnings

- Read all installation instructions and site survey reports, and verify correct equipment installation before connecting the Altitude 4600 Access Point to its power source.
- Remove jewelry and watches before installing this equipment.
- Verify that the unit is grounded before connecting it to the power source.
- Verify any device connected to this unit is properly wired and grounded.
- Connect all power cords to a properly wired and grounded electrical circuit.
- Verify the electrical circuits have appropriate overload protection.
- Attach only approved power cords to the device.
- Verify the power connector and socket are accessible at all times during the operation of the equipment.
- Do not work with power circuits in dimly lit spaces.
- Do not install this equipment or work with its power circuits during thunderstorms or other weather conditions that could cause a power surge.
- Verify there is adequate ventilation around the device, and that ambient temperatures meet equipment operation specifications.

Site Preparation

- Consult your site survey and network analysis reports to determine specific equipment placement, power drops, and so on.
- Assign installation responsibility to the appropriate personnel.
- Identify and document where all installed components are located.
- Provide a sufficient number of power drops for your equipment.
- Ensure adequate, dust-free ventilation to all installed equipment.
- Identify and prepare Ethernet and console port connections.
- Verify cable lengths are within the maximum allowable distances for optimal signal transmission.

Package Contents

An Altitude 4600 Series Access Point comes in eight hardware configurations, four integrated (internal) antenna models and four external antenna models. The contents of the package differ between the integrated antenna model and the external antenna model. Both single and dual radio models are supported.

External Antenna Models - Package Contents (AP4620-US, AP4621-US, AP4620-ROW and AP4621-ROW)

- Altitude 4600 Series Access Point with external antenna connectors (Plenum Rated)
- Six dual-band (2.4/5 GHz) dipole antennas (AP4620 dual-radio model), or three dual-band (2.4/5 GHz) dipole antennas (AP4611 single-radio model)
- Two wall mount screws
- Two wall anchors
- Light pipe
- Badge for light pipe
- *Altitude 4600 Series Access Point Installation Guide* (This Guide)

Integrated Antenna Models - Package Contents (AP4610-US, AP4611-US, AP4610-ROW and AP4611-ROW)

- Altitude 4600 Series Access Point with integrated antennas
- Two wall mount screws
- Two wall anchors
- *Altitude 4600 Series Access Point Installation Guide* (This Guide)

Features

An Altitude 4600 Series Access Point ships with the following features:

- One RJ-45 connector
- LED indicators
- Safety wire tie point
- Slots for wall mounting
- Clips for mounting on a suspended ceiling T-bar
- Lock port for Kensington® style Security Lock

An Altitude 4600 Series Access Point has one RJ-45 connector supporting an 10/100/1000 Ethernet port and requires 802.3af-compliant power from an external source.



NOTE

When operating in a Gigabit Ethernet environment CAT-5e or CAT-6 cable is required for Gigabit operation.

An Altitude 4600 Series Access Point comes in both single and dual radio versions both supporting 802.11a/b/g/n.

An Altitude 4600 Series Access Point contains runtime firmware which enables the unit to boot after either a power up or a watchdog reset. The runtime firmware on the access point and the firmware downloaded from the controller can be updated via the Ethernet interface from the controller.

Installation Instructions

An Altitude 4600 Series Access Point mounts either on a wall with wide-shoulder screws or on a suspended ceiling T-bar. This unit is not designed for mounting on a desk.

To prepare for installation, perform the following steps:

- 1 Match the model number on the purchase order with the model numbers in the packing list and on the case of the Altitude 4600 Series Access Point.
- 2 Verify the contents of the box includes the correct Altitude 4600 model access point.
 - AP4610-US - 802.11a/b/g/n dual radio integrated antenna configuration for the US regulatory domain (Part Number: 15724)
 - AP4611-US - 802.11a/b/g/n single radio integrated antenna configuration for the US regulatory domain (Part Number: 15757)
 - AP4610-ROW - 802.11a/b/g/n dual radio integrated antenna configuration for the ROW (Rest of World domain except Israel) regulatory domain (Part Number: 15725)
 - AP4611-ROW - 802.11a/b/g/n single radio integrated antenna configuration for the ROW (Rest of World domain except Israel) regulatory domain (Part Number: 15735)
 - AP4620-US - 802.11a/b/g/n dual radio external antenna configuration for the US regulatory domain (Part Number: 15730)
 - AP4621-US - 802.11a/b/g/n single radio external antenna configuration for the US regulatory domain (Part Number: 15758)
 - AP4620-ROW - 802.11a/b/g/n dual radio external antenna configuration for the ROW (Rest of World domain except Israel) regulatory domain (Part Number: 15731)
 - AP4621-ROW - 802.11a/b/g/n single radio external antenna configuration for the ROW (Rest of World domain except Israel) regulatory domain (Part Number: 15749)
- 3 Review site survey and network analysis reports to determine the location and mounting position for the access point.

- 4 Connect a CAT-5 or better Ethernet cable to a compatible 802.3af power source and run the cable to the installation site. Ensure there is sufficient slack on the cable to perform the installation steps.



NOTE

When operating in a Gigabit Ethernet environment CAT-5e or CAT-6 cable is required for Gigabit operation.

Precautions

Before installing an Altitude 4600 Series Access Point, verify the following:

- The intended deployment site is not a wet or dusty area.
- The environment has a continuous temperature range between 0° C to 50° C.

Access Point Placement

For optimal performance, install the Altitude 4600 Series Access Point away from transformers, heavy-duty motors, fluorescent lights, microwave ovens, refrigerators and other industrial equipment. Signal loss can occur when metal, concrete, walls or floors block transmission. Install the access point in an open area or add access points as needed to improve coverage.

Antenna coverage is analogous to lighting. Users might find an area lit from far away to be not bright enough. An area lit sharply might minimize coverage and create dark areas. Uniform antenna placement in an area (like even placement of a light bulb) provides even, efficient coverage.

Place the access point using the following guidelines:

- Install the access point at an ideal height of 10 feet from the ground.
- Orient the access point antennas vertically for best reception.

To maximize the access point's radio coverage area, Extreme Networks® recommends conducting a site survey to define and document radio interference obstacles before installing an Altitude 4600 Series Access Point.

Integrated Antenna Model Wall Mount Instructions

This mounting requires hanging the access point along its width or length using the two slots on the bottom of the unit. An Altitude 4600 Series Access Point can be mounted onto any plaster, wood, or cement wall surface using the provided wall anchors. The illustration in the following section shows a lengthwise mount.

Wall Mount Hardware

The following hardware is required to complete the wall mount of an Altitude 4600 Series Access Point:

- Two wide-shoulder Phillips pan head self-tapping screws
- Two wall anchors
- Security cable (optional)



NOTE

In the event the original mounting screws are lost, the following screws can be used: (ANSI Standard) #6-18 X 0.875in. Type A or AB Self-Tapping Screw, or (ANSI Standard Metric) M3.5 X 0.6 X 20mm Type D Self-Tapping Screw.

Wall Mount Procedure

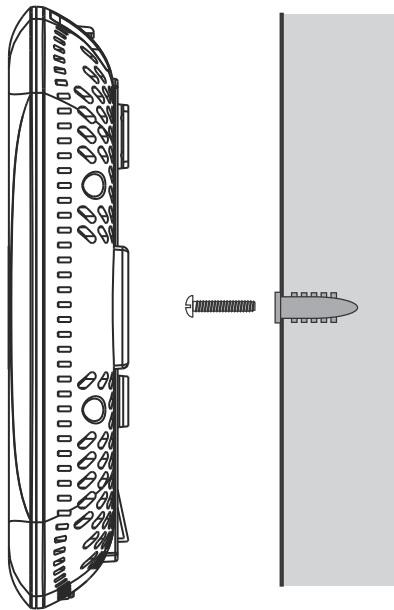

Integrated Antenna Wall Mount

- 1 Orient the unit on the wall by its width or length.
- 2 Using the arrows on one edge of the case as guides, move the edge to the midline of the mounting area and mark points on the midline for the screws.
- 3 At each point, drill a hole in the wall, insert an anchor, screw into the anchor the wall mounting screw and stop when there is 1mm between the screw head and the wall.



NOTE

When pre-drilling a hole the recommended hole size is 2.8mm (0.11in.) if the screws are going directly into the wall and 6mm (0.23in.) if the provided wall anchors are being used.

- 4 If required, install and attach a security cable to the unit's lock port.
- 5 Attach the Ethernet cable to the unit and to a controller with an 802.3af-compatible power source.
- 6 Place the middle of each of the case's mount slots over the screw heads.
- 7 Slide the case down along the mounting surface to hang the mount slots on the screw heads.
- 8 Verify the unit has power by observing that the LEDs are lit or flashing.

Integrated Antenna Suspended Ceiling T-Bar Mount Instructions

Ceiling mount requires holding the Altitude 4600 Series Access Point up against the T-bar of a suspended ceiling grid and twisting the case onto the T-bar.

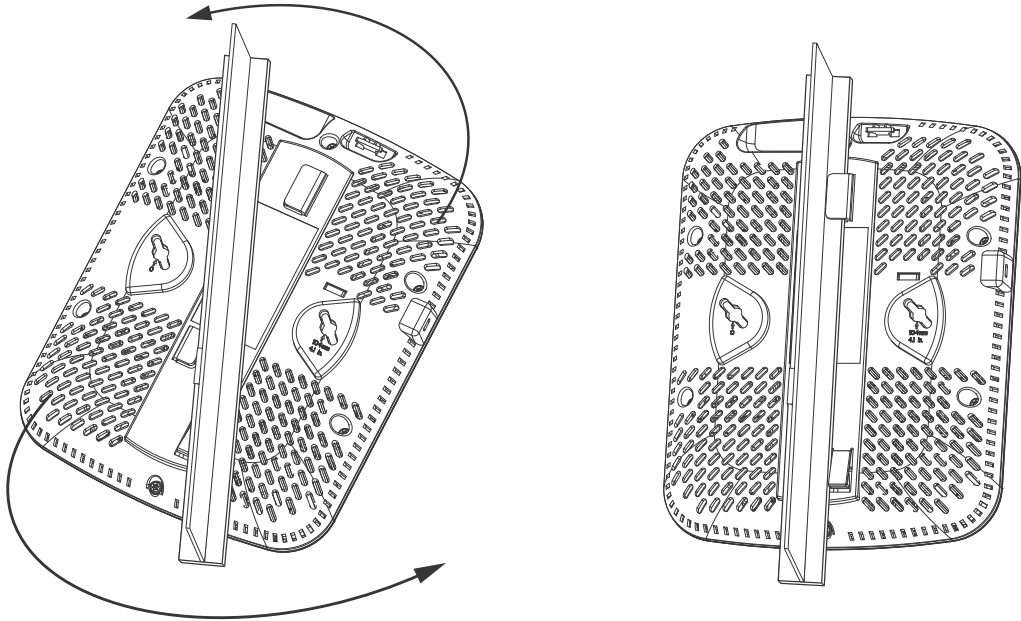

- 1 If required, install and attach a security cable to the unit's lock port.
- 2 Plug the Ethernet cable into the unit and to a switch with an 802.3af-compatible power source.
- 3 Face the bottom of the T-bar with the back of the case.
- 4 Orient the case by its length and the length of the T-bar.
- 5 Rotate the case in place 45 degrees clockwise, or about 10 o'clock.
- 6 Push the back of the case onto the bottom of the T-bar.
- 7 Rotate the case 45 degrees counter-clockwise. The clips click as they fasten to the T-bar.
- 8 Verify the unit has power by observing the LEDs.

External Antenna Wall Mount Instructions

Wall mounting requires hanging an Altitude 4600 Series Access Point along its width or length using the pair of slots on the bottom of the unit. The access point can be mounted on to any plaster, wood, or cement wall surface using the provided wall anchors when necessary. The illustration on the next page shows a lengthwise mount.

Wall Mount Hardware

The following hardware is required to complete the wall mount of an Altitude 4600 Series Access Point (external antenna version):

- Two wide-shoulder Phillips pan head self-tapping screws
- Two wall anchors
- Safety wire (recommended) and a security cable (optional)



NOTE

In the event that the original mounting screws are lost, the following screws can be used instead: (ANSI Standard) #6-18 X 0.875in. Type A or AB Self-Tapping Screw, or (ANSI Standard Metric) M3.5 X 0.6 X 20mm Type D Self-Tapping Screw.

Wall Mount Procedure

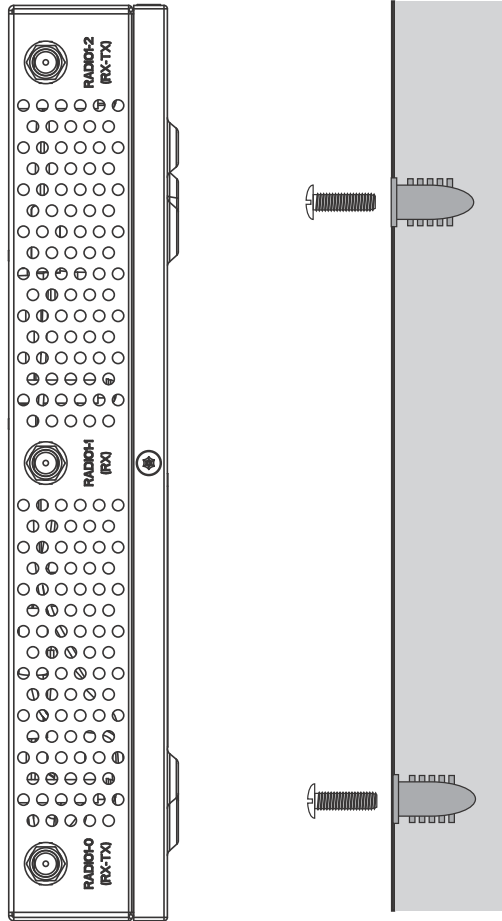

- 1 Orient the case on the wall by its width or length.
- 2 Using the arrows on one edge of the case as guides, move the edge to the midline of the mounting area and mark points on the midline for the screws.
- 3 At each point, drill a hole in the wall, insert an anchor, screw into the anchor the wall mounting screw and stop when there is 1mm between the screw head and the wall.



NOTE

When pre-drilling a hole the recommended hole size is 2.8mm (0.11in.) if the screws are going directly into the wall and 6mm (0.23in.) if the provided wall anchors are being used.

- 4 If required, loop a safety wire, between 1.5mm (.06in.) and 2.5mm (.10in.) in diameter, around the tie post and secure the loop.
- 5 If required, install and attach a security cable to the unit's lock port.
- 6 Place the large corner of each of the case's mount slots over the screw heads.
- 7 Slide the case down along the mounting surface to hang the mount slots on the screw heads.
- 8 Attach appropriate antennas to the connectors.
- 9 Attach the Ethernet cable to the unit and to a switch with an 802.3af compatible power source.
- 10 Verify the unit has power by observing that the LEDs are lit or flashing.

External Antenna Suspended Ceiling Tile (Plenum) Mount Instructions

Ceiling mount requires placing an Altitude 4600 Series Access Point above a suspended ceiling and installing the provided light pipe for viewing the status lights of the unit.



NOTE

Notes or warnings about suspended ceiling mounts apply to all installations where the unit is placed on suspended ceiling tile. The case has a safety wire tie point for a standard safety wire.



CAUTION

Extreme Networks does not recommend mounting an Altitude 4600 Series Access Point directly to a suspended ceiling tile with a thickness less than 12.7mm (0.5in.) or a suspended ceiling tile with an unsupported span greater than 660mm (26in.). Extreme Networks strongly recommends fitting the access point with a safety wire suitable for the specific installation. The safety wire should be a standard ceiling suspension cable or equivalent steel wire between 1.59mm (.062in.) and 2.5mm (.10in.) in diameter.

This placement requires installation of the provided light pipe for viewing the status lights of the unit.

Suspended Ceiling Mount Hardware

- Light pipe
- Badge for light pipe
- Safety wire (recommended) and security cable (optional)

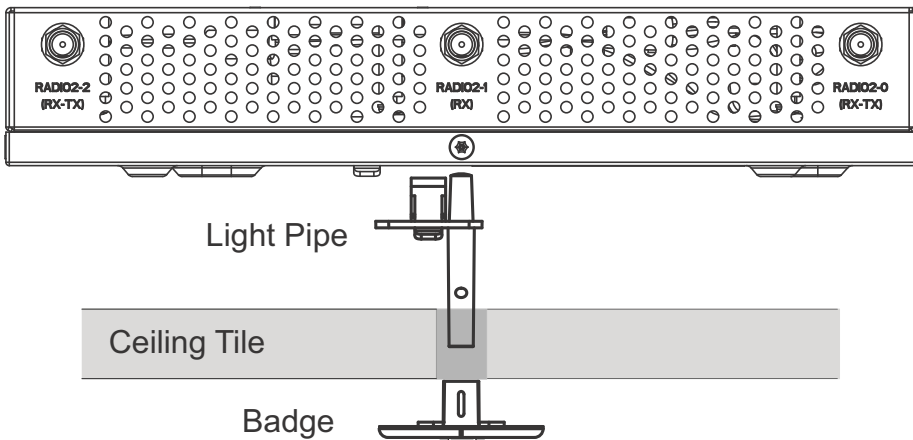

Ceiling Mount Procedure

To mount the Altitude 4600 Series Access Point on a ceiling:

- 1 If possible, remove the ceiling tile from its frame and place it, finished side down, on a work surface.
- 2 If required, install a safety wire, between 1.5mm (.06in.) and 2.5mm (.10in.) in diameter, in the ceiling space.
- 3 If required, install and attach a security cable to the unit's lock port.
- 4 Mark a point on the upper or unfinished side of the tile.
- 5 Push the light pipe through the tile at the mark and remove the light pipe. If necessary, use a drill to make a hole in the tile.
- 6 Attach appropriate antennas to the connectors.

- 7 Snap the clips of the light pipe into the bottom of the case.
- 8 Fit the light pipe into hole in the tile from its unfinished side.
- 9 Attach any safety wire to the safety wire tie point or security cable to the unit's lock port.
- 10 Bring the tile into the ceiling space.
- 11 Plug the Ethernet cable into the unit and to a switch with an 802.3af-compatible power source.
- 12 Verify the unit has power by observing the LEDs.
- 13 Place the ceiling tile back in its frame.
- 14 Snap the badge onto the light pipe from the finished side of the tile.

Altitude 4600 Series Antenna Options

Extreme Networks supports two antenna suites for the external antenna model. One antenna suite supporting the 2.4 GHz band and another antenna suite supporting the 5 GHz band. Select an antenna model best suited to the intended operational environment of your external antenna model. On single radio versions, the R-SMA connectors can support both bands and should be connected to an R-SMA dual-band antenna or an appropriate single band antenna. See the *Altitude 35xx/46xx AP Antenna Selection Guide* or the *Altitude 35xx/46xx/47xx AP Antenna Selection Guide* available from <http://www.extremenetworks.com/go/documentation> for details.

LED Indicators

Both the integrated antenna model and external antenna model have LED activity indicators on the front of the case for use with wall mount deployments. With the external antenna model unit mounted above a ceiling, LEDs are at the center of an oval badge on the ceiling; a light pipe enables viewing the back LEDs through the ceiling tile.

The LEDs provide a status display indicating error conditions, transmission, and network activity for the 5 GHz 802.11a/n (amber) radio or the 2.4 GHz 802.11b/g/n (green) radio.

The LED behavior is determined by the version of software running on the controller which the access point is connected to. The tables below show the LED patterns for software version 4.x and software version 5.x.

Software Version 4.x LED States

Task	5 GHz Activity LED (Amber)	2.4 GHz Activity LED (Green)
Unadopted	Off	Blinking at 5Hz
Normal Operation	If this radio band is enabled: Blink rate at 5 second interval If this radio band is disabled: Off If there is activity on this band: Blink rate at a 1Hz	If this radio band is enabled: Blink rate at 5 second interval If this radio band is disabled: Off If there is activity on this band: Blink rate at a 1Hz
Firmware Update	On	Off
Locate AP Mode	Blink rate at 5Hz (Out of Phase with Activity LED)	Blink rate at 5Hz (Out of Phase with Activity LED)

Software Version 5.x LED States

Task	5 GHz Activity LED (Amber)	2.4 GHz Activity LED (Green)
System Booting	Solid On (During start up only)	Solid On (During start up only)
Radio Shutdown Administratively or LEDs Disabled	Off	Off
Locate AP Mode	Off	Blinking
Firmware Upgrade	Solid	Off
Adopted (not configured)	Solid	Solid
Sensor Mode (Connected to server)	Blink (On 1 second, Off 1 second)	Blink (On 1 second, Off 1 second)
Sensor Mode (Not connected to server)	Blink (On 1 second, Off 5 seconds)	Blink (On 1 second, Off 5 seconds)

3 Specifications

Electrical Characteristics

Both external and internal antenna model Altitude 4600 Series Access Point have the following electrical characteristics:

Operating Voltage and Current: 48V DC, 180ma - 270mA

An Altitude 4600 Series Access Point can receive power in one of following ways:

- 1 Power over Ethernet (PoE) - If your network is already set up with a Gigabit PoE injector (802.3af compliant), attach the LAN Ethernet cable to the access point's LAN port.
- 2 Power over Ethernet: Adding PoE injector - If your network is not set up with PoE, you can provide power to the Ethernet cable with a Gigabit PoE injector. The Gigabit PoE injector must be 802.3af compliant. The Gigabit PoE injector is not provided with the Altitude 4600 Series Access Point.

Option number 2 suggests a pre-approved Gigabit Ethernet rated mid-span PoE power injector that is either IEEE 802.3af or 802.3at compliant can be used as an external power source for Altitude 4600 series access points. The device must have NRTL listings for use in the US or appropriate regulatory approvals for countries outside the US.

External Antenna Model Physical Characteristics

An external antenna model Altitude 4600 Series Access Point has the following physical characteristics:

Dimensions	8.50 in. Depth x 5.5 in. Width x 1.5 in. Height 21.59 cm Depth x 13.97 cm Width x 3.81 cm Height
Housing	Metal

Specifications

Weight	2.5 lbs / 1.13 kg
Operating Temperature	32°F to 122°F / 0°C to 50°C
Storage Temperature	-40°F to 158°F / -40°C to 70°C
Operating Humidity	5 to 95% Relative Humidity non-condensing
Storage Humidity	85% Relative Humidity non-condensing
Operating Altitude (max)	8,000 ft @ 28C
Storage Altitude (max)	30,000 ft @ 12C
Electrostatic Discharge	+/-15kV Air and +/-8kV Contact @ 50% Relative Humidity

Integrated Antenna Model Physical Characteristics

An integrated antenna model Altitude 4600 Series Access Point has the following physical characteristics:

Dimensions	9.50 in. Depth x 7.5 in. Width x 1.9 in. Height 24.13 cm Depth x 19.05 cm Width x 4.83 cm Height
Housing	Plastic
Weight	2.0 lbs / 0.91 kg
Operating Temperature	32°F to 122°F / 0°C to 50°C
Storage Temperature	-40°F to 158°F / -40°C to 70°C
Operating Humidity	5 to 95% Relative Humidity non-condensing
Storage Humidity	85% Relative Humidity non-condensing
Operating Altitude (max)	8,000 ft @ 28C
Storage Altitude (max)	30,000 ft @ 12C
Electrostatic Discharge	+/-15kV Air and +/-8kV Contact @ 50% Relative Humidity

Radio Characteristics

Both the integrated and external antenna model Altitude 4600 Series Access Points have the following radio characteristics:

Operating Channels	All channels from 4920 MHz to 5825 MHz except channel 52 -64 Channels 1-13 (2412-2472 MHz) Channel 14 (2484 MHz) Japan only Actual operating frequencies depend on regulatory approval for the country of use.
Supported Data Rates	802.11g: 1,2,5.5,11,6,9,12,18,24,36,48, and 54Mbps 802.11a: 6,9,12,18,24,36,48, and 54Mbps 802.11n: MCS 0-15 up to 300Mbps
Wireless Medium	<i>Direct Sequence Spread Spectrum (DSSS), Orthogonal Frequency Division Multiplexing (OFDM) Spatial multiplexing (MIMO)</i>
Network Standards	802.11a, 802.11b, 802.11g, 802.3, 802.11n (Draft 2.0)
Maximum Available Transmit Power	Maximum available conducted transmit power per chain: 2.4 GHz: 21dBm Maximum available conducted transmit power all chains: 2.4 GHz: 24dBm Maximum available conducted transmit power per chain: 5 GHz: 19dBm Maximum available conducted transmit power all chains: 5 GHz: 22dBm
Transmit Power Adjustment	1dB increments
Antenna Configuration	2x3 MIMO (transmit on two and receive on all three antennas)

Establishing Basic AP Connectivity

This section defines the steps required to establish basic AP connectivity with an Extreme Networks Summit® WM3000 series controller.

Prerequisites for connecting an Altitude 4600 Series Access Point to a controller include:

- Ensure your controller has an appropriate access point capacity license.
- Ensure the controller is up and running on the network and is reachable from the network on which the AP is installed.
- Refer to the controller installation guide and *Summit WM3000 Series Controller System Reference Guide* for details.

Access Point Controller Adoption

Access point adoption is the process of a controller accepting the access point's device radios for use within the controller managed network. The access point's radio(s) encapsulates every packet and sends them to the controller.

When the controller and the AP are in same Layer 2 domain, the AP can discover the controller and gets adopted by the controller automatically. It is plug-n-play and no other configuration is required. If the AP and controller are across a subnet, the process defined in the next paragraph is required for AP adoption.

The Altitude 4600 Series Access Point and WLAN controller support standard and vendor specific DHCP options which can be supplied from a DHCP server to the Altitude 4600 Series Access Point operating as a DHCP client. The DHCP options can be enabled on the DHCP server to automate management functions such as firmware image and configuration file updates as well as provide the necessary information to an access point for automatic controller discovery allowing for plug and play access point deployment.

An Altitude 4600 Series Access Points support the following DHCP vendor options:

Code	Description	Format
189	WLAN controller IP Address	ASCII or String

DHCP option 189 can be supplied with the DHCP Offer to provide an Altitude 4600 Series Access Points with one or more WLAN controller IP addresses which the Altitude 4600 Series Access Point will attempt to connect to. WLAN controller IP addresses can be separated with multiple delimiters including a space, comma and semi colon.

Code	Format	Example
189	String	192.168.10.14 192.168.10.15 192.168.10.16 192.168.10.14,192.168.10.15, 192.168.10.16 192.168.10.14;192.168.10.15;192.168.10.16

5

Regulatory Compliance

This device is approved under the Motorola brand.

The Extreme Networks Altitude AP4600 Series Access Points are manufactured by Motorola and are exactly the same as the Motorola model AP-650 Series Access Point except for brand name and product label. See the following link for Extreme Networks Declaration of Similarity (DoS) and Declaration of Conformity (DoC):

<http://www.extremenetworks.com/go/rfcertification.htm>.

This guide applies to Extreme Networks AP4600 series access points:

Part Number	Model Number	Regulatory Domain
15724	Altitude AP4610-US 11abgn InAn AP	For use in the US only
15725	Altitude AP4610-ROW 11abgn InAn AP	For use in Europe & Rest of World domain except Israel (RoW)
15757	Altitude AP4611-US 11abgn InAn AP	For use in the US only
15735	Altitude AP4611-ROW 11abgn InAn AP	For use in Europe & Rest of World domain except Israel (RoW)
15730	Altitude AP4620-US 11abgn ExAn AP	For use in the US only
15731	Altitude AP4620-ROW 11abgn ExAn AP	For use in Europe & Rest of World domain except Israel (RoW)
15758	Altitude AP4621-US 11abgn ExAn AP	For use in the US only
15749	Altitude AP4621-ROW 11abgn ExAn AP	For use in Europe & Rest of World domain except Israel (RoW)

All Extreme Networks devices are designed to be compliant with rules and regulations in locations they are sold and will be labeled as required.

Local language translations are available at the following website:

<http://support.symbol.com> under AP-650.

Any changes or modifications to Extreme Networks equipment, not expressly approved by Motorola, could void the user's authority to operate the equipment.

Extreme Networks access points must be professionally installed and configured so that the Radio Frequency Output Power will not exceed the maximum allowable limit for the country of operation.



WARNING!

Antennas: Use only the supplied or an approved replacement antenna. Unauthorized antennas, modifications, or attachments could cause damage and may violate regulations. Use of an unapproved antenna is illegal under FCC regulations subjecting the end user to fines and equipment seizure. See the *Altitude 35xx/46xx AP Antenna Selection Guide* or *Altitude 35xx/46xx/47xx AP Antenna Selection Guide* available from <http://www.extremenetworks.com/go/documentation> for details.

Radio Modules

This access point contains approved radio module(s) MB82. These module(s) are identified below.

MB82 - a DFS Master WLAN 802.11 abgn MIMO 2x3 radio module.

Wireless Device Country Approvals

Regulatory markings, subject to certification, are applied to the device signifying the radio(s) is/are approved for use in the following countries: United States, Canada, Japan, Australia, and Europe.

Please refer to the country list located at:
<http://www.extremenetworks.com/go/rfcertification.htm>.



NOTE

For 2.4GHz or 5GHz Products: Europe includes, Austria, Belgium, Bulgaria, Czech Republic, Cyprus, Denmark, Estonia, Finland, France, Germany, Greece, Hungary, Iceland, Ireland, Italy, Latvia, Liechtenstein, Lithuania, Luxembourg, Malta, Netherlands, Norway, Poland, Portugal, Romania, Slovak Republic, Slovenia, Spain, Sweden, Switzerland and the United Kingdom.



WARNING!

Operation of the device without regulatory approval is illegal.

Country Selection - Note for AP & Wireless Switch

Select only the country in which you are using the device. Any other selection will make the operation of this device illegal. The US version of the Access Point will only have US listed in the country selection table. The US version will be sold / used in the US protectorates: American Samoa, Guam, Puerto Rico, US Virgin Islands.

The AP4600 series ROW models will list many countries where it's the professional installer's and end user's responsibility to properly follow these instructions to set-up the access point.

Although outdoor use may be allowed and may be restricted to certain frequencies and/or may require a license for operation, the Altitude 4600 Series Access Point is intended for indoor use and must be installed in a proper indoor location. Use the installation utility provided with the controller software to ensure proper set-up in accordance with all European spectrum usage rules. Contact local Authority for procedure to follow and regulatory information.

Frequency of Operation - FCC and IC

5 GHz Only

The use on UNII (Unlicensed National Information Infrastructure) Band 1 5150 - 5250 MHz and Band 3 5470 - 5725 MHz is restricted to indoor use only, any other use will make the operation of this device illegal.

Devices using the 5470 - 5725 MHz band shall not be capable of transmitting in the band 5600 - 5650 MHz in the US, this "Notched" band has been disabled in the US version of the Access Point.

The available channels for 802.11 b/g operation in the US are Channels 1 to 11. The range of channels is limited by firmware.

2.4 GHz Only

The available channels for 802.11 b/g operation in the US are Channels 1 to 11. The range of channels is limited by firmware.

Health and Safety Recommendations

Warnings for the use of Wireless Devices

Please observe *all* warning notices with regard to the usage of wireless devices.

Potentially Hazardous Atmospheres - Fixed Installations

You are reminded of the need to observe restrictions on the use of radio devices in fuel depots, chemical plants etc. and areas where the air contains chemicals or particles (such as grain, dust, or metal powders).

Safety in Hospitals



Wireless devices transmit radio frequency energy and may affect medical electrical equipment. When installed adjacent to other equipment, it is advised to verify that the adjacent equipment is not adversely affected.

Pacemakers

Pacemaker manufacturers recommended that a minimum of 15cm (6 inches) be maintained between a handheld wireless device and a pacemaker to avoid potential interference with the pacemaker. These recommendations are consistent with independent research and recommendations by Wireless Technology Research.

Persons with Pacemakers:

- Should ALWAYS keep the device more than 15cm (6 inches) from their pacemaker when turned ON.
- Should not carry the device in a breast pocket.
- Should use the ear furthest from the pacemaker to minimize the potential for interference.
- If you have any reason to suspect that interference is taking place, turn OFF your device.

Other Medical Devices

Please consult your physician or the manufacturer of the medical device, to determine if the operation of your wireless product may interfere with the medical device.

RF Exposure Guidelines

Safety Information

Reducing RF Exposure—Use Properly

Only operate the device in accordance with the instructions supplied.

International

The device complies with internationally recognized standards covering human exposure to electromagnetic fields from radio devices. For information on “International” human exposure to electromagnetic fields refer to the Extreme Networks Declaration of Conformity (DoC) at <http://www.extremenetworks.com/go/rfcertification.htm>.

EU

Remote and Standalone Antenna Configurations

To comply with EU RF exposure requirements, antennas that are mounted externally at remote locations or operating near users at standalone desktop of similar configurations must operate with a minimum separation distance of 20 cm from all persons.

US and Canada

Co-located statement

To comply with FCC RF exposure compliance requirement, the antennas used for this transmitter must not be co-located or operating in conjunction with any other transmitter/antenna except those already approved in this filing.

Remote and Standalone Antenna Configurations

To comply with FCC RF exposure requirements, antennas that are mounted externally at remote locations or operating near users at stand-alone desktop of similar configurations must operate with a minimum separation distance of 20 cm from all persons.

Power Supply

This device is powered from an 802.3af compliant power source which is UL approved and certified by the appropriate agencies.

Radio Frequency Interference Requirements - FCC



This equipment has been tested and found to comply with the limits for a Class B digital device, pursuant to Part 15 of the FCC rules. These limits are designed to provide reasonable protection against harmful interference in a residential installation. This equipment generates, uses and can radiate radio frequency energy and, if not installed and used in accordance with the instructions, may cause harmful interference to radio communications. However there is no guarantee that interference will not occur in a particular installation. If this equipment does cause harmful interference to radio or television reception, which can be determined by turning the equipment off and on, the user is encouraged to try to correct the interference by one or more of the following measures:

- Reorient or relocate the receiving antenna
- Increase the separation between the equipment and receiver
- Connect the equipment into an outlet on a circuit different from that to which the receiver is connected
- Consult the dealer or an experienced radio/TV technician for help

Radio Transmitters (Part 15)

This device complies with Part 15 of the FCC Rules. Operation is subject to the following two conditions: (1) this device may not cause harmful interference, and (2) this device must accept any interference received, including interference that may cause undesired operation.

Restricted Band 5.60-5.65 GHz

Radio Frequency Interference Requirements - Canada

This Class B digital apparatus complies with Canadian ICES-003.

Cet appareil numérique de la classe B est conforme à la norme NMB-003 du Canada.

Radio Transmitters

For RLAN Devices:

The use of 5 GHz RLANs, for use in Canada, have the following restrictions:

- Restricted Band 5.60 – 5.65 GHz

This device complies with RSS 210 of Industry & Science Canada. Operation is subject to the following two conditions: (1) this device may not cause harmful interference and (2) this device must accept any interference received, including interference that may cause undesired operation.

Label Marking: The Term "IC:" before the radio certification signifies that Industry Canada technical specifications were met.

CE Marking and European Economic Area (EEA)



The use of 2.4 GHz RLANs, for use through the EEA, have the following restrictions:

- Maximum radiated transmit power of 100 mW EIRP in the frequency range 2.400 - 2.4835 GHz.
- France, outside usage is restricted to 2.4-2.454 GHz.
- Italy requires a user license for outside usage.

Statement of Compliance

Extreme Networks hereby, declares that this device is in compliance with the essential requirements and other relevant provisions of Directive 1999/5/EC. A Declaration of Conformity may be obtained from <http://www.extremenetworks.com/go/rfcertification.htm>.

Turkish WEEE Statement of Compliance

EEE Yönetmeliğine Uygundur

Japan (VCCI) - Voluntary Control Council for Interference Class B ITE

この装置は、情報処理装置等電波障害自主規制協議会（VCCI）の基準に基づくクラスB情報技術装置です。この装置は、家庭環境で使用することを目的としていますが、この装置がラジオやテレビジョン受信機に近接して使用されると、受信障害を引き起こすことがあります。取扱説明書に従って正しい取り扱いをして下さい。

This is a Class B product based on the standard of the Voluntary Control Council for Interference from Information Technology Equipment (VCCI). If this is used near a radio or television receiver in a domestic environment, it may cause radio interference. Install and use the equipment according to the instruction manual.

Korea Warning Statement for Class B ITE

기종별	사용자안내문
B 급 기기 (가정용 방송통신기기)	이 기기는 가정용 (B 급) 으로 전자과적합등록을 한 기기로서 주로 가정에서 사용하는 것을 목적으로 하며, 모든 지역에서 사용할 수 있습니다.
Class B (Broadcasting Communication Device for Home Use)	This device obtained EMC registration mainly for home use (Class B) and may be used in all areas.

Other Countries

Australia

Use of 5 GHz RLANS in Australia is restricted in the following band 5.50-5.65 GHz.

Brazil

Regulatory declarations for AP-650 - BRAZIL

Note: The certification mark applied to the AP-650 is for Restrict Radiation Equipment. This equipment operates on a secondary basis and does not have the right for protection against harmful interference from other users including same equipment types. Also this equipment must not cause interference to systems operating on primary basis.

For more information consult the website <http://www.anatel.gov.br>

Declarações Regulamentares para AP-650 - Brasil

Nota: "A marca de certificação se aplica ao Transceptor, modelo AP-650. Este equipamento opera em caráter secundário, isto é, não tem direito a proteção contra interferência prejudicial, mesmo de estações do mesmo tipo, e não pode causar interferência a sistemas operando em caráter primário."

Para maiores informações sobre ANATEL consulte o site: <http://www.anatel.gov.br>

Chile

"Este equipo cumple con la Resolución No 403 de 2008, de la Subsecretaria de telecomunicaciones, relativa a radiaciones electromagnéticas."

"This device complies with the Resolution Not 403 of 2008, of the Undersecretary of telecommunications, relating to electromagnetic radiation."

Mexico

Restrict Frequency Range to: 2.450 - 2.4835 GHz.

Taiwan

NOTICE!

According to: Administrative Regulations on Low Power Radio Waves Radiated Devices

Article 12

Without permission granted by the DGT, any company, enterprise, or user is not allowed to change frequency, enhance transmitting power or alter original characteristic as well as performance to an approved low power radio-frequency devices.

Article 14

The low power radio-frequency devices shall not influence aircraft security and interfere legal communications; if found, the user shall cease operating immediately until no interference is achieved.

The said legal communications means radio communications is operated in compliance with the Telecommunications Act.

The low power radio-frequency devices must be susceptible with the interference from legal communications or ISM radio wave radiated devices.

臺灣

低功率電波輻射性電機管理辦法

第十二條

經型式認證合格之低功率射頻電機，非經許可，公司、商號或使用者均不得擅自變更頻率、加大功率或變更原設計之特性及功能。

第十四條

低功率射頻電機之使用不得影響飛航安全及干擾合法通信；經發現有干擾現象時，應立即停用，並改善至無干擾時方得繼續使用。

前項合法通信，指依電信規定作業之無線電通信。

低功率射頻電機須忍受合法通信或工業、科學及醫療用電波輻射性電機設備之干擾。

Wireless device operate in the frequency band of 5.25-5.35 GHz, limited for Indoor use only.

在 5.25-5.35 赫頻帶內操作之無線資訊傳輸設備，限於室內使用。

Korea

For a radio equipment using 2400~2483.5MHz or 5725~5825MHz, the following two expressions should be displayed:

- 1 “This radio equipment can be interfered during operation.”

당해 무선설비는 운용 중 전파혼신 가능성이 있음

- 2 “This radio equipment cannot provide a service relevant to the human life safety, as it can be crossed” through the user manual etc.

당해 무선설비는 전파혼신 가능성이 있으므로 인명안전과 관련된 서비스는 할 수 없습니다

**6**

Waste Electrical and Electronic Equipment (WEEE)

English: For EU Customers: All products at the end of their life must be returned to Extreme Networks for recycling. For information on how to return product, please go to: <http://www.extremenetworks.com/go/eu-weee>.

Čeština: Pro zákazníky z EU: Všechny produkty je nutné po skončení jejich životnosti vrátit společnosti Symbol k recyklaci. Informace o způsobu vrácení produktu najdete na webové stránce: <http://www.extremenetworks.com/go/eu-weee>

Dansk: Til kunder i EU: Alle produkter skal returneres til Extreme Networks til recirkulering, når de er udtjent. Læs oplysningerne om returnering af produkter på: <http://www.extremenetworks.com/go/eu-weee>.

Deutsch: Für Kunden innerhalb der EU: Alle Produkte müssen am Ende ihrer Lebensdauer zum Recycling an Extreme Networks zurückgesandt werden. Informationen zur Rücksendung von Produkten finden Sie unter <http://www.extremenetworks.com/go/eu-weee>.

Eesti: EL klientidele: kõik tooted tuleb nende eluea lõppedes tagastada taaskasutamise eesmärgil Extreme Networks'ile. Lisainformatsiooni saamiseks toote tagastamise kohta külastage palun aadressi: <http://www.extremenetworks.com/go/eu-weee>.

Español: Para clientes en la Unión Europea: todos los productos deberán entregarse a Extreme Networks al final de su ciclo de vida para que sean reciclados. Si desea más información sobre cómo devolver un producto, visite: <http://www.extremenetworks.com/go/eu-weee>.

Ελληνικά: Για πελάτες στην Ε.Ε.: Όλα τα προϊόντα, στο τέλος της διάρκειας ζωής τους, πρέπει να επιστρέφονται στην Symbol για ανακύκλωση. Για περισσότερες πληροφορίες σχετικά με την επιστροφή ενός προϊόντος, επισκεφθείτε τη διεύθυνση <http://www.extremenetworks.com/go/eu-weee>

Français : Clients de l'Union Européenne : Tous les produits en fin de cycle de vie doivent être retournés à Extreme Networks pour recyclage. Pour de plus amples informations sur le retour de produits, consultez : <http://www.extremenetworks.com/go/eu-weee>.

Italiano: per i clienti dell'UE: tutti i prodotti che sono giunti al termine del rispettivo ciclo di vita devono essere restituiti a Extreme Networks al fine di consentirne il riciclaggio. Per informazioni sulle modalità di restituzione, visitare il seguente sito Web: <http://www.extremenetworks.com/go/eu-weee>.

Latviešu: ES klientiem: visi produkti pēc to kalpošanas mūža beigām ir jānogādā atpakaļ Symbol otrreizējai pārstrādei. Lai iegūtu informāciju par produktu nogādāšanu Symbol, lūdzu, skatiet: <http://www.extremenetworks.com/go/eu-weee>

Lietuvių: ES vartotojams: visi gaminiai, pasibaigus jų eksploatacijos laikui, turi būti gražinti utilizuoti į kompaniją „Symbol“. Daugiau informacijos, kaip gražinti gaminį, rasite: <http://www.extremenetworks.com/go/eu-weee>

Magyar: Az EU-ban vásárlóknak: Minden tönkrement termékét a Extreme Networks vállalathoz kell eljuttatni újrahazsnósfítás céljából. A termék visszajuttatásának módjával kapcsolatos tudnivalókért látogasson el a <http://www.extremenetworks.com/go/eu-weee> weboldalra

Malti: Għal klijenti fl-UE: il-prodotti kollha li jkunu waslu fl-aħħar tal-hajja ta' l-użu tagħhom, iridu jġu rritornati għand Symbol għar-riċiklaġġ. Għal aktar tagħrif dwar kif għandek tirritorna l-prodott, jekk jogħġbok żur: <http://www.extremenetworks.com/go/eu-weee>

Nederlands: Voor klanten in de EU: alle producten dienen aan het einde van hun levensduur naar Extreme Networks te worden teruggezonden voor recycling. Raadpleeg <http://www.extremenetworks.com/go/eu-weee> voor meer informatie over het terugzenden van producten.

Polski: Klienci z obszaru Unii Europejskiej: Produkty wycofane z eksploatacji należy zwrócić do firmy Symbol w celu ich utylizacji. Informacje na temat zwrotu produktów znajdują się na stronie internetowej <http://www.extremenetworks.com/go/eu-weee>

Português: Para clientes da UE: todos os produtos no fim de vida devem ser devolvidos à Extreme Networks para reciclagem. Para obter informações sobre como devolver o produto, visite: <http://www.extremenetworks.com/go/eu-weee>.

Slovenski: Za kupce v EU: vsi izdelki se morajo po poteku življenjske dobe vrniti podjetju Extreme Networks za reciklažo. Za informacije o vračilu izdelka obiščite: <http://www.extremenetworks.com/go/eu-weee>.

Slovenščina: Pre zákazníkov z krajín EU: Všetky výrobky musia byť po uplynutí doby ich životnosti vrátené spoločnosti Symbol na recykláciu. Bližšie informácie o vrátení výrobkov nájdete na: <http://www.extremenetworks.com/go/eu-weee>

Suomi: Asiakkaat Euroopan unionin alueella: Kaikki tuotteet on palautettava kierrätettäväksi Extreme Networks-yhtiöön, kun tuotetta ei enää käytetä. Lisätietoja tuotteiden palauttamisesta on osoitteessa <http://www.extremenetworks.com/go/eu-weee>.



NOTE

Services can be purchased from Extreme Networks or through one of its channel partners. If you are an end-user who has purchased service through an Extreme Networks channel partner, please contact your partner first for support.

Extreme Networks Technical Assistance Centers (TAC) provide 24x7x365 worldwide coverage. These centers are the focal point of contact for post-sales technical and network-related questions or issues. TAC will create a Service Request (SR) number and manage all aspects of the SR until it is resolved. For a complete guide to customer support, see the *Technical Assistance Center User Guide* at:

<http://www.extremenetworks.com/go/TACUserGuide>

The Extreme Networks eSupport website provides the latest information on Extreme Networks products, including the latest Release Notes, troubleshooting, downloadable updates or patches as appropriate, and other useful information and resources. Directions for contacting the Extreme Networks Technical Assistance Centers are also available from the eSupport website at:

<https://esupport.extremenetworks.com>

Registration

If you have not already registered with Extreme Networks using a registration card supplied with your product, you can register on the Extreme Networks website at:

<http://www.extremenetworks.com/go/productregistration>.

Documentation

Check for the latest versions of documentation on the Extreme Networks documentation website at:

<http://www.extremenetworks.com/go/documentation>

